

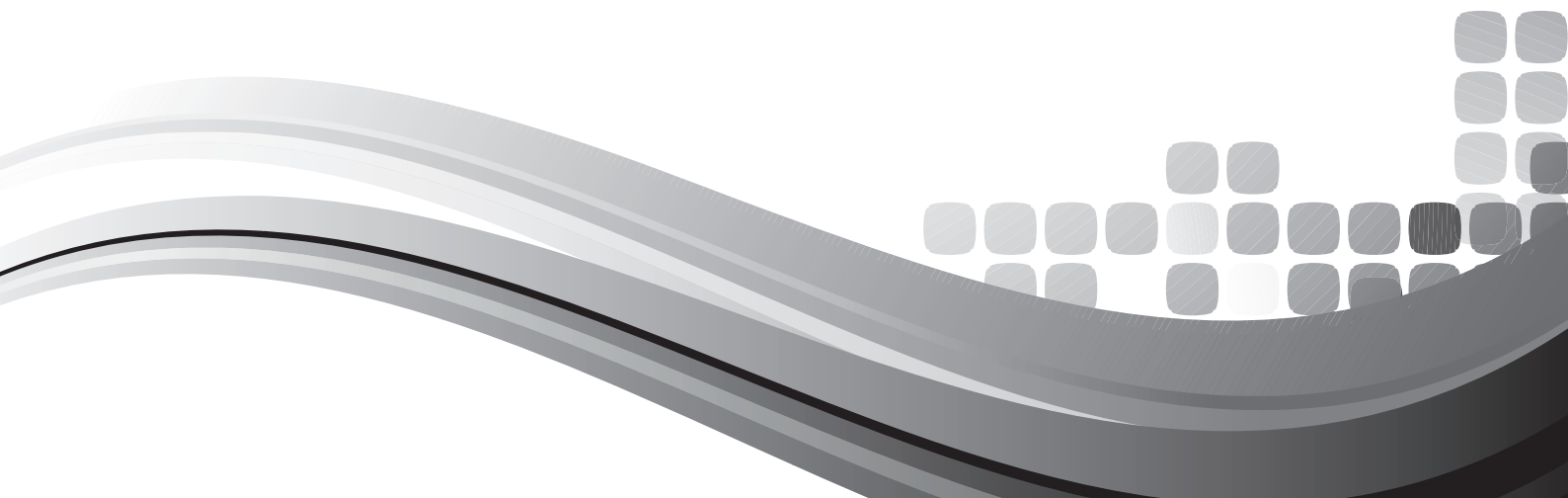

# INSTALLATION AND OPERATION MANUAL

# AMPAV40

ACTIVE THREE WAY  
STEREO SPEAKER SYSTEM



## IMPORTANT SAFETY INFORMATION

1. Read these instructions.
2. Keep these instructions.
3. Heed all warnings.
4. Follow all instructions.
5. Do not use this apparatus near water.
6. Clean only with dry cloth.
7. Do not block any ventilation openings. Install in accordance with the manufacturer's instructions.
8. Do not install near any heat sources such as radiators, heat registers, stoves, or other apparatus (including amplifiers) that produce heat.
9. Do not defeat the safety purpose of the polarized or grounding-type plug. A polarized plug has two blades with one wider than the other. A grounding type plug has two blades and a third grounding prong. The wide blade or the third prong are provided for your safety. If the provided plug does not fit into your outlet, consult an electrician for replacement of the obsolete outlet.
10. Protect the power cord from being walked on or pinched particularly at plugs, convenience receptacles, and the point where they exit from the apparatus.
11. Only use attachments/accessories specified by the manufacturer.
12. Use only with the cart, stand, tripod, bracket, or table specified by the manufacturer, or sold with the apparatus. When a cart is used, use caution when moving the cart/apparatus combination to avoid injury from tip-over.
13. Unplug this apparatus during lightning storms or when unused for long periods of time.
14. Refer all servicing to qualified service personnel. Servicing is required when the apparatus has been damaged in any way, such as power-supply cord or plug is damaged, liquid has been spilled or objects have fallen into the apparatus, the apparatus has been exposed to rain or moisture, does not operate normally, or has been dropped.
15. This appliance shall not be exposed to dripping or splashing water and that no object filled with liquid such as vases shall be placed on the apparatus.
16. Plug this apparatus to the proper wall outlet and make the plug to be disconnected readily operable.
17. Mains plug is used as disconnected device and it should remain readily operable during intended use. In order to disconnect the apparatus from the mains completely, the mains plug should be disconnected from the mains socket outlet completely.
18. **WARNING:** To reduce the risk of fire or electric shock, do not expose this apparatus to rain or moisture.
19. An appliance with a protective earth terminal should be connected to a mains outlet with a protective earth connection.
20. The apparatus should be disconnected from the mains completely before speaker wiring. The speaker output should be proper protected from direct contact and pay attention to speaker connections, terminals and speaker wiring during normal operation.



## PRÉCAUTIONS DURANT UTILISATION

1. LISEZ ces instructions.
2. Tenez ces instructions.
3. Notez tous les avertissements.
4. Suivez toutes les avertissements.
5. N'utilisez pas ce produit près de l'eau (la piscine, la plage, le lac, etc.).
6. Nettoyez seulement avec une étoffe sèche.
7. Ne bloquez aucuns trous de ventilation. Installez en accord avec les instructions du fabricant.
8. N'installez près aucunes sources de chaleur comme radiateurs, registres de chaleur, fours ou les autres équipements (y compris amplificateurs) qui produisent la chaleur.
9. Ne défaites pas le but de sécurité de la fiche polarisée ou base-type. Une fiche polarisée a deux tranchants avec un plus large que l'autre. Une fiche de base type a deux tranchants et une troisième pointe de base, le tranchant large ou la troisième pointe est fourni pour votre sécurité. Si la fiche donnée ne conforme pas votre prise de contact, consultez un électricien pour remplacement de la prise de contact obsolète.
10. Protégez le cordon de secteur contre être marchée dessus ou pincez en particulier aux fiches, aux douilles de convenance, et au point où ils sortent de l'appareil.
11. Seulement utilisez attachements/accessoires spécifiés par le fabricant.
12. Utilisez seulement avec un chariot, un stand, un trépied, un support ou une table indiquée par le fabricant, ou vendue avec l'appareil. Quand un chariot est utilisé, faites attention en déplaçant la combinaison d'appareil/chariot pour éviter de se déséquilibrer.
13. Arrachez la fiche du dispositif durant éclair et orage ou quand pas utilisé pour longues périodes de temps.
14. Référez au personnel qualifié de service pour toutes réparations. La réparation est donnée quand le système a été endommagé à n'importe façon, par exemple un fil ou une fiche endommagé(e) de la source d'alimentation. Avoir été exposé à pluie ou humidité, n'opère pas normalement, ou avoir été tombé.
15. L'appareil ne doit pas être exposé aux écoulements ou aux éclaboussures et aucun objet ne contenant de liquide, tel qu'un vase, ne doit être placé sur l'objet.
16. Branchez l'appareil à une source appropriée et faire que la prise à débrancher soit facilement accessible.
17. La prise du secteur ne doit pas être obstruée ou doit être facilement accessible pendant son utilisation. Pour être complètement déconnecté de l'alimentation d'entrée, la prise doit être débranchée du secteur.
18. **AVERTISSEMENT:** Pour éviter le risque d'incendie ou de chocs électriques, ne pas exposer cet appareil à la pluie ou à l'humidité.
19. Un appareil avec la borne de terre de protection doit être connecté au secteur avec la connexion de terre de protection.
20. Assurez-vous que l'appareil est hors tension avant de connecter les hauts parleurs. Vérifiez que la sortie des enceintes soit protégées contre un contact physique. Respecter les polarités des terminaux ainsi que le câblage des enceintes pendant le fonctionnement afin d'assurer une utilisation sécurisée.





## AMPAV40

The Australian Monitor AMPAV40 is an active three-way stereo speaker system consisting of one powered and one passive speaker. The speakers are compact, architecturally pleasing and come supplied with adjustable mounting brackets. Features include an on-board 20 W stereo amplifier, Treble, Bass and Volume controls, unbalanced stereo RCA inputs and balanced stereo line inputs as well as remote control operation and USB support.

The AMPAV40 features a 5.25" bass driver, 0.5" dynamic mid-range tweeter and a 1" piezo high frequency tweeter delivering a solid 2 x 20 watts RMS of clear, intelligible power.

The Australian Monitor AMPAV series powered speakers deliver a new standard of high quality sound reinforcement for a variety of audio visual applications. Compact and well designed, they are easy to operate and are set to become the standard in many AV installations. The speakers are available in white (AMPAV40W) and black (AMPAV40B).

INTRODUCTION	3
AMPAV40 FRONT PANEL – ACTIVE & PASSIVE	4
AMPAV40 REAR PANEL – ACTIVE	5
AMPAV40 REAR PANEL – ACTIVE & PASSIVE	6
REMOTE	7
MOUNTING	8
DIMENSIONS	9
SPECIFICATIONS	10
NOTES	11

Revision 1.1 February 2016

### WARNING!

TO PREVENT FIRE OR SHOCK HAZARD, DO NOT USE THE PLUG WITH AN EXTENSION CORD, RECEPTACLE OR OTHER OUTLET UNLESS THE BLADES CAN BE FULLY INSERTED TO PREVENT BLADE EXPOSURE.

TO REDUCE THE RISK OF FIRE OR ELECTRIC SHOCK, DO NOT EXPOSE THIS APPLIANCE TO RAIN OR MOISTURE.

TO PREVENT ELECTRICAL SHOCK, MATCH WIDE BLADE PLUG TO WIDE SLOT & FULLY INSERT.

### CAUTION

THESE SERVICING INSTRUCTIONS ARE FOR USE BY QUALIFIED SERVICE PERSONNEL ONLY. TO REDUCE THE RISK OF ELECTRIC SHOCK DO NOT PERFORM ANY SERVICING OTHER THAN THAT CONTAINED IN THE OPERATING INSTRUCTIONS UNLESS YOU ARE QUALIFIED TO DO SO.



The lightning flash with arrowhead symbol, within an equilateral triangle, is intended to alert the user to the presence of uninsulated "dangerous voltage" within the product's enclosure that may be of sufficient magnitude to constitute a risk of electric shock to persons.



**WARNING:**  
TO REDUCE THE RISK OF ELECTRIC SHOCK, DO NOT REMOVE COVER (OR BACK). NO USER SERVICEABLE PARTS INSIDE. REFER SERVICING TO QUALIFIED SERVICE PERSONNEL.



The exclamation point within an equilateral triangle is intended to alert the user to the presence of important operating and maintenance (servicing) instructions in the literature accompanying the appliance.



For European Union countries: This symbol on the product or its packaging indicates that this product must not be disposed of with other waste. Instead, it is your responsibility to dispose of your waste equipment by handing it over to a designated collection point for the recycling of waste electrical and electronic equipment. Please contact your local authority for further details of your nearest designated collection point.

Rating plate and caution marking are marked on the back enclosure of the apparatus



## AMPAV40 FRONT PANEL – ACTIVE AND PASSIVE

GRILL REMOVED

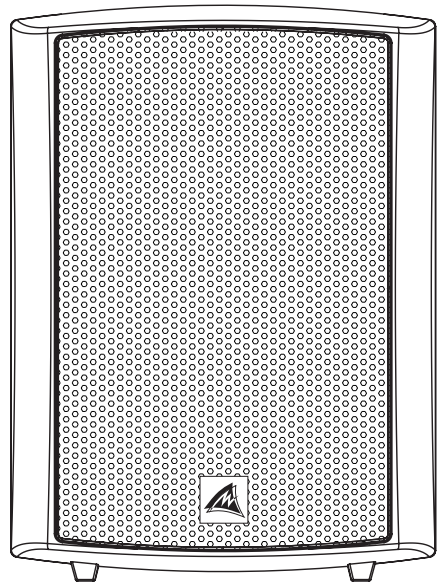
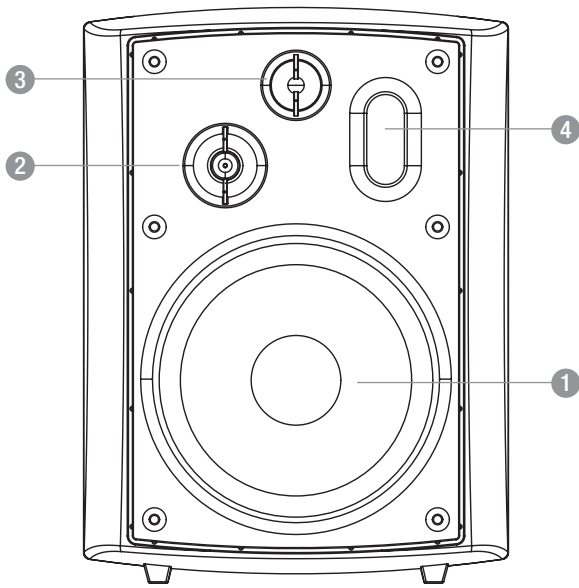

- ① 5.25" Bass Driver
- ② 0.5" Dynamic Tweeter
- ③ 1.0" Piezo Tweeter
- ④ Bass Port



## ACTIVE

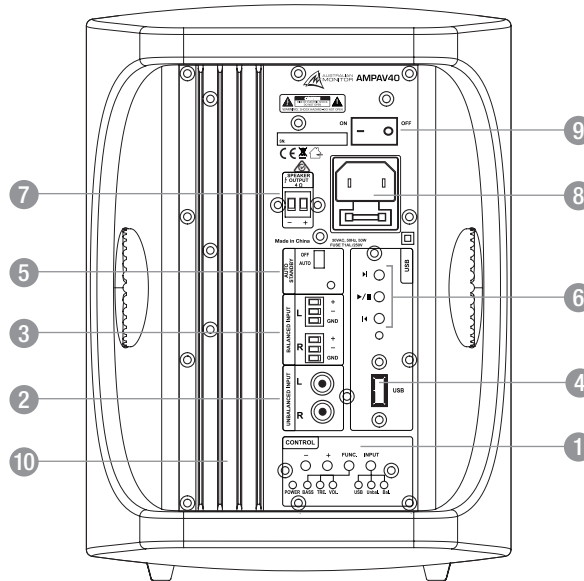

The AMPAV40 has a number of functions and input options which may be selected from the active speaker's rear panel or from the supplied remote control.

### 1 Control

#### Power:

A power LED indicator on the control panel segment indicates when power is on (red) or when the system is in standby (orange).

#### Input:

Each input option is identified by an associated green LED. Selection is made by pressing the INPUT button successive times until the required input is chosen. Input options include; USB, Unbalanced and Balanced.

#### Func:

Pressing the FUNC (function) button toggles operation between the Bass, Treble or Volume controls and the selection is indicated by a red LED. Once the function is selected, press the "+" or "-" button successively to set the required parameter.

### 2 Unbalanced Input

Unbalanced stereo RCA inputs (Left and Right) are provided for connection of devices such as CD and DVD players, computers, data projector audio etc.

### 3 Balanced Input

Balanced stereo line inputs (Left and Right) are provided by 3 pin terminal sockets and come fitted with removable screw terminal plugs. These screw terminal inputs are high impedance and set to line level. The inputs are marked as "+" and "-" for the incoming line and GND for the shielding ground of your balanced cable.

**NOTE:** Because both the unbalanced and balanced inputs are set at "line level" to suit most external audio sources, the inputs are not suitable for connecting a microphone directly. This requires a suitable microphone mixer as the output level of a microphone is considerably lower than line level sources.

### 4 USB

Input connection port for a USB memory stick.

Be sure to switch the INPUT to USB, a red LED indicates when USB has been selected. Playing will start immediately after a USB stick has been inserted into the speaker. When a USB program is being played, the red LED flashes to indicate it is in use. Do not remove the USB stick whilst this is occurring, pause the program or change the input before unplugging the stick to avoid damage. The AMPAV40 is capable of playing recordings in both WMA and MP3 formats.

**NOTE:** The USB port is designed for USB sticks and does not support connection of a PC or laptop.

### 5 USB Controls

Control buttons are provided for all the usual functions required to play ►, forward ⏩, reverse ⏪ and pause ⏸ tracks on the USB stick. As this device does not have a visual display, you should be aware of the track locations you require when programming your USB stick.

### 6 Auto Standby

The Standby switch allows the system to engage the auto standby function.

#### AUTO mode:

In Auto mode, the speaker enters into standby (sleep) mode if no audio signal is detected for approximately three minutes. Standby mode is identified by a STANDBY green LED indicator on the rear panel.

The speaker will turn on automatically when it detects an audio signal and the LED will extinguish.

#### OFF mode:

The "OFF" button disables the Auto mode feature.

*continued over page*



## PASSIVE

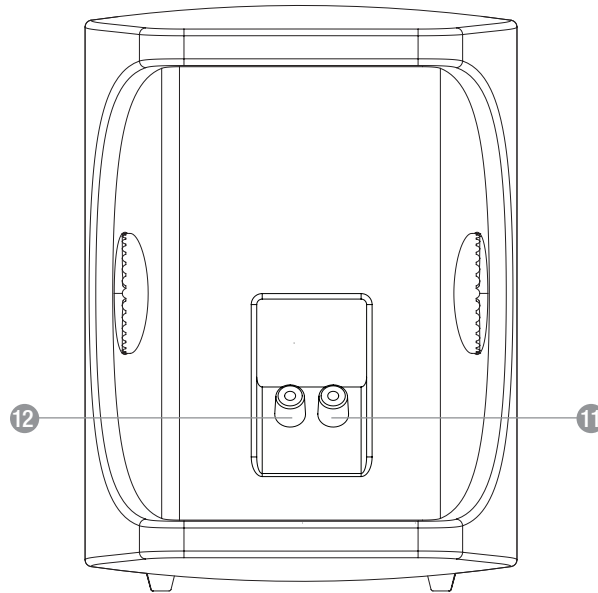

### 7 Speaker Output 4 $\Omega$

Connection to the passive 4 Ohm external speaker is provided through a two pin terminal socket and comes fitted with removable screw terminal plug. The passive speaker becomes the right hand channel whilst the left channel is the active speaker. Connect the supplied figure 8 or a similar speaker cable between the active and passive speaker. Be sure that the “+” of the main unit is connected to the “+” (red terminal post) of the passive loudspeaker and the “-” of the main unit is connected to the “-” (black terminal post) of the passive speaker.

Never connect the active Speaker Output terminal to an external speaker that is not the correct 4 Ohm impedance.

### 8 IEC Power Supply Socket

 The integrated IEC and fuse holder socket is fitted with a 1 Amp slow blow fuse. An IEC mains power cable is supplied with the unit.

Should the fuse require replacement, use a screw driver to open the fuse compartment. A spare fuse is contained in the tray under the IEC socket. Always ensure that a 1 A slow blow fuse is used.

Never replace a fuse without first turning off the speaker and unplugging the mains cable from the wall outlet.

### 9 Power ON/OFF

 The Power switch turns the speaker system on and off. When the unit is switched on, a red ON LED will illuminate to indicate that the system is operational. Always ensure that the power is turned off when connecting or disconnecting the speaker cabling to the speaker.

### 10 Heat Sink

 When using your speakers at full power and over a long period, the heat sink may become hot, this is normal, do not touch it! Take care when placing the speaker too close to other items that may be heat sensitive.

Be careful during installation not to route any cabling through the heat sink area as damage may occur.

### 11 Positive Terminal

### 12 Negative Terminal

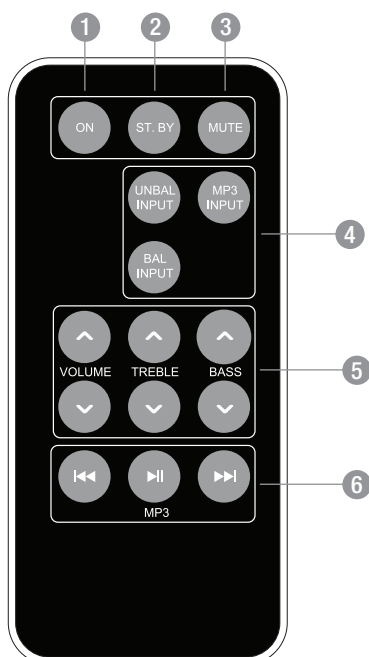

The AMPAV40 speaker is turned on from the mains switch at the rear of the unit. Once activated, the remote control can then be used to operate the speaker remotely including setting the speaker system to standby mode when not in use.

**1 ON**

This command will turn the unit on when in standby mode. The power LED will change from orange to red.

**2 ST.BY**

Pressing ST.BY places the speaker system into standby mode. The indicator LED turns orange.

**3 MUTE**

Enables or disables the audio.

**4 UNBAL INPUT, BAL INPUT, USB/MP3**

These three buttons are used to select the required input; Unbalanced, Balanced or USB port. You can change to the appropriate input by simply pressing the associated button.

**5 VOLUME, TREBLE, BASS**

You can select and adjust the volume, bass and treble of the speaker set by using these controls.

**6 USB/MP3**

These buttons allows you to control tracks that are stored on the USB stick using the standard player commands; play, pause, forward and reverse tracks (refer to section 4 of the manual under USB for more information).



# MOUNTING

## MOUNTING

**!** When mounting AMPAV speakers the following safety issues must be considered.

The mounting of a permanently installed speaker may be dangerous unless undertaken by a qualified professional with relevant experience.

Walls and mounting surfaces must be capable of supporting the speaker and bracket in a safe and secure manner.

All fixings must be safely attached to the speaker cabinet and the mounting surface.

All fixings must be installed in accordance with the manufacturer's instructions and specifications.

## MOUNTING BRACKETS

The AMPAV speakers are supplied with horizontal wall mount U brackets allowing adjustment in the vertical plane.

Slots for mounting the brackets are 5 mm wide and spaced 80 mm apart. The design of the slots allows for the bracket to be easily mounted and removed. Simply secure the bracket to the wall using suitable fittings but always ensure that they are fit for purpose. Once the bracket is secure, mount the speaker to the bracket and connect wiring.

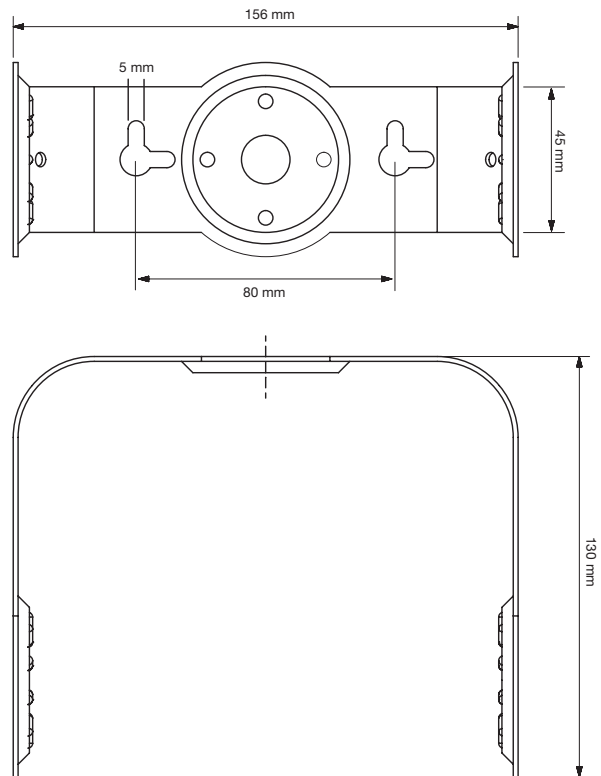
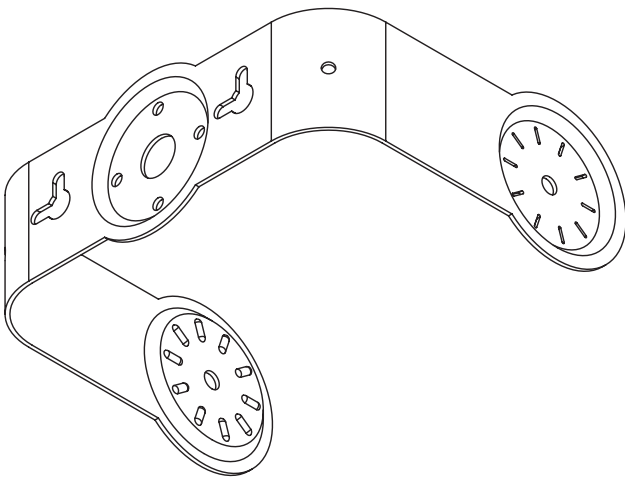

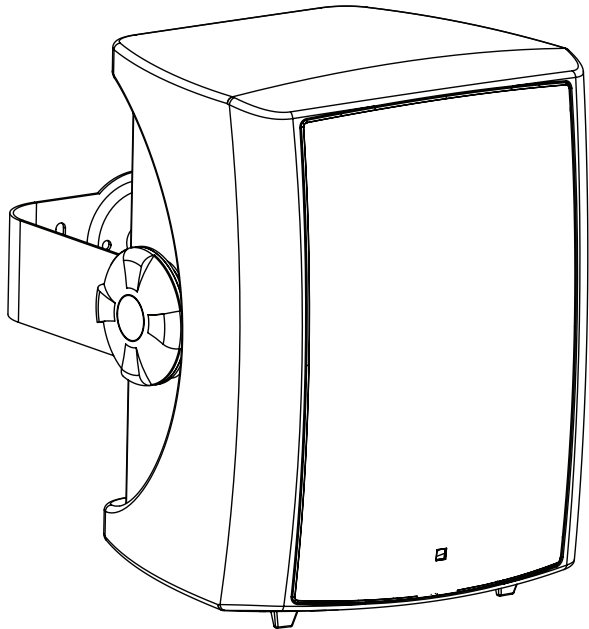
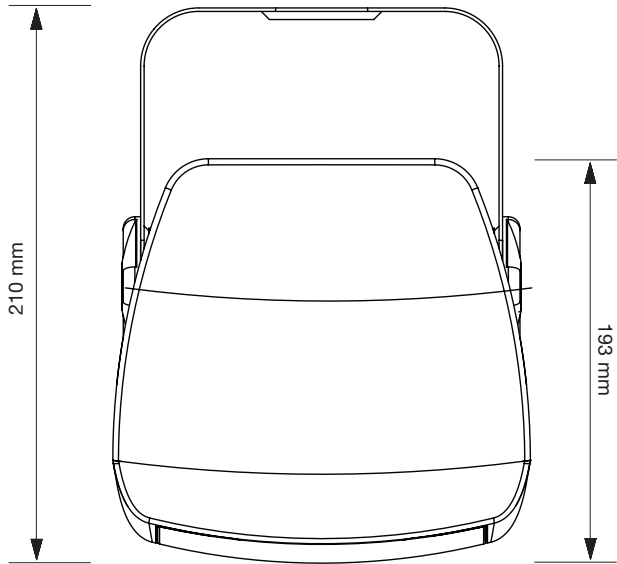
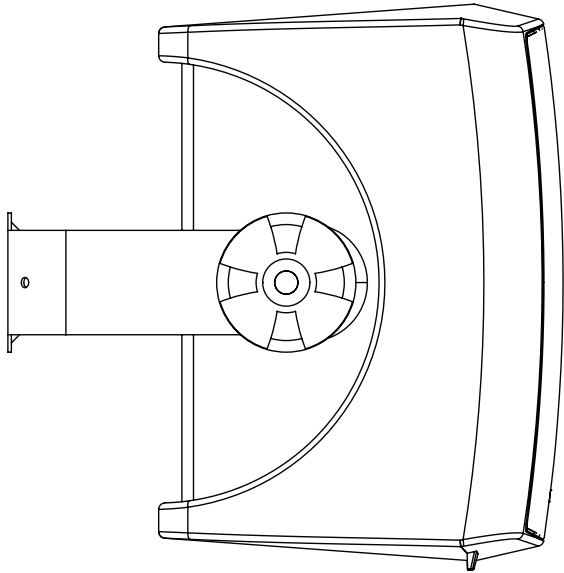
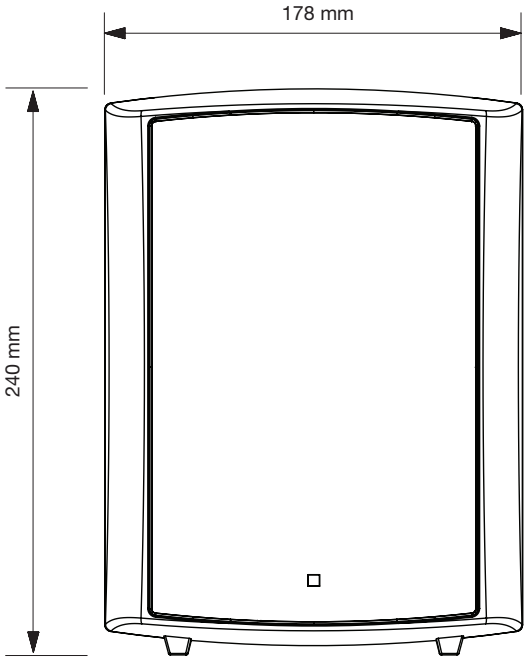





## SPECIFICATIONS

## AMPAV40

<b>Speaker system</b>	3-Way Active Speaker 3-Way Passive Speaker
<b>Power (Continuous)</b>	2 x 20 Watts
<b>Impedance</b>	4 Ohms
<b>Sensitivity (1 W / 1 M)</b>	88 dB
<b>Calculated max SPL (per speaker)</b>	101 dB
<b>Frequency Response (-3 dB)</b>	45 Hz – 20 kHz
<b>Frequency Response (-10 dB)</b>	40 Hz – 22 kHz
<b>Speaker Components Woofer</b>	134 mm (5.25") Polypropylene 25 mm (1") Piezo Tweeter 12.5 mm (0.5") Dynamic Tweeter
<b>Mains Power Requirement</b>	230 VAC, 50 Hz, 50 W
<b>Dimensions (W x H x D) (each speaker)</b>	178 x 240 x 193 mm (7" x 9.4" x 7.5")
<b>Dimensions (W x H x D) (boxed pair)</b>	465 x 270 x 205 mm (18.3" x 10.6" x 8.1")
<b>Weight (active speaker)</b>	2.9 kg (6.3lbs)
<b>Weight (passive speaker)</b>	1.9 kg (4.2 lbs)
<b>Gross Weight per pair (box)</b>	5.9 kg (13.0 lbs)
<b>Accessories (supplied)</b>	Passive Speaker Wall brackets (pair) Bracket fixing "dials" (pair) 1.65 M IEC mains cord 2.6 M Figure-8 speaker wire Installation & Operation Manual



ENGINEERED BY AUSTRALIAN MONITOR

Address: 1 Clyde Street, Silverwater NSW 2128 Australia.

Website: [www.australianmonitor.com.au](http://www.australianmonitor.com.au) International enquiries email: [international@australianmonitor.com.au](mailto:international@australianmonitor.com.au)