

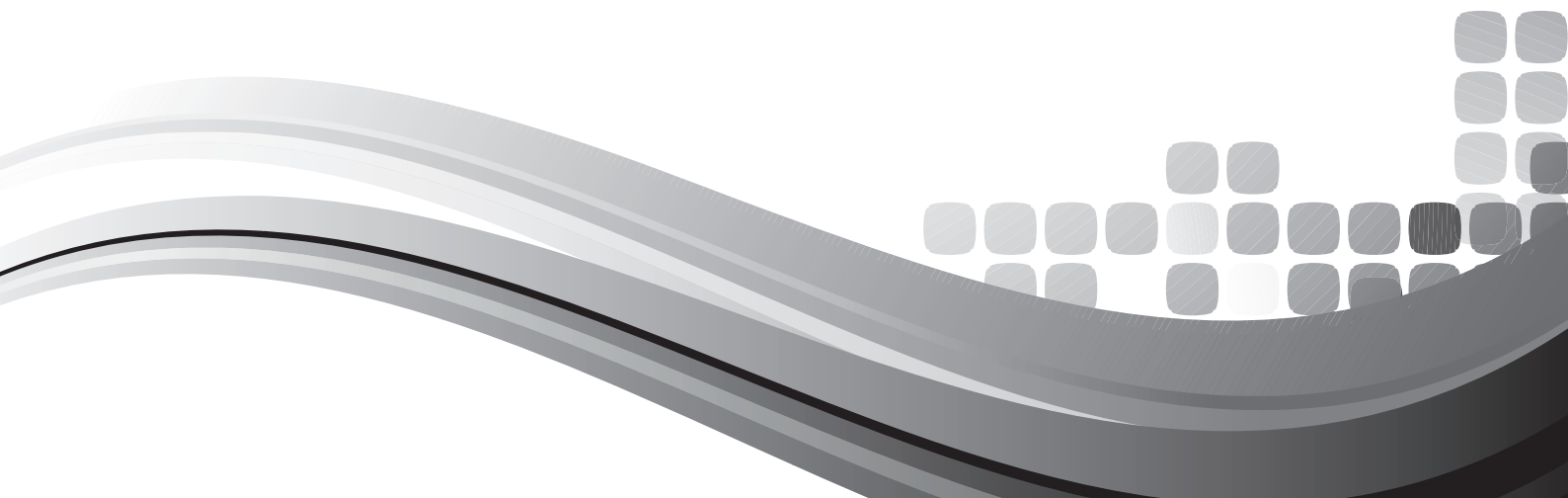

INSTALLATION AND OPERATION MANUAL

AMPAV30

ACTIVE THREE WAY
STEREO SPEAKER SYSTEM



IMPORTANT SAFETY INFORMATION

1. Read these instructions.
2. Keep these instructions.
3. Heed all warnings.
4. Follow all instructions.
5. Do not use this apparatus near water.
6. Clean only with dry cloth.
7. Do not block any ventilation openings. Install in accordance with the manufacturer's instructions.
8. Do not install near any heat sources such as radiators, heat registers, stoves, or other apparatus (including amplifiers) that produce heat.
9. Do not defeat the safety purpose of the polarized or grounding-type plug. A polarized plug has two blades with one wider than the other. A grounding type plug has two blades and a third grounding prong. The wide blade or the third prong are provided for your safety. If the provided plug does not fit into your outlet, consult an electrician for replacement of the obsolete outlet.
10. Protect the power cord from being walked on or pinched particularly at plugs, convenience receptacles, and the point where they exit from the apparatus.
11. Only use attachments/accessories specified by the manufacturer.
12. Use only with the cart, stand, tripod, bracket, or table specified by the manufacturer, or sold with the apparatus. When a cart is used, use caution when moving the cart/apparatus combination to avoid injury from tip-over.
13. Unplug this apparatus during lightning storms or when unused for long periods of time.
14. Refer all servicing to qualified service personnel. Servicing is required when the apparatus has been damaged in any way, such as power-supply cord or plug is damaged, liquid has been spilled or objects have fallen into the apparatus, the apparatus has been exposed to rain or moisture, does not operate normally, or has been dropped.
15. This appliance shall not be exposed to dripping or splashing water and that no object filled with liquid such as vases shall be placed on the apparatus.
16. Plug this apparatus to the proper wall outlet and make the plug to be disconnected readily operable.
17. Mains plug is used as disconnected device and it should remain readily operable during intended use. In order to disconnect the apparatus from the mains completely, the mains plug should be disconnected from the mains socket outlet completely.
18. **WARNING:** To reduce the risk of fire or electric shock, do not expose this apparatus to rain or moisture.
19. An appliance with a protective earth terminal should be connected to a mains outlet with a protective earth connection.
20. The apparatus should be disconnected from the mains completely before speaker wiring. The speaker output should be proper protected from direct contact and pay attention to speaker connections, terminals and speaker wiring during normal operation.



PRÉCAUTIONS DURANT UTILISATION

1. LISEZ ces instructions.
2. Tenez ces instructions.
3. Notez tous les avertissements.
4. Suivez toutes les avertissements.
5. N'utilisez pas ce produit près de l'eau (la piscine, la plage, le lac, etc.).
6. Nettoyez seulement avec une étoffe sèche.
7. Ne bloquez aucuns trous de ventilation. Installez en accord avec les instructions du fabricant.
8. N'installez près aucunes sources de chaleur comme radiateurs, registres de chaleur, fours ou les autres équipements (y compris amplificateurs) qui produisent la chaleur.
9. Ne défaites pas le but de sécurité de la fiche polarisée ou base-type. Une fiche polarisée a deux tranchants avec un plus large que l'autre. Une fiche de base type a deux tranchants et une troisième pointe de base, le tranchant large ou la troisième pointe est fourni pour votre sécurité. Si la fiche donnée ne conforme pas votre prise de contact, consultez un électricien pour remplacement de la prise de contact obsolète.
10. Protégez le cordon de secteur contre être marchée dessus ou pincez en particulier aux fiches, aux douilles de convenance, et au point où ils sortent de l'appareil.
11. Seulement utilisez attachements/accessoires spécifiés par le fabricant.
12. Utilisez seulement avec un chariot, un stand, un trépied, un support ou une table indiquée par le fabricant, ou vendue avec l'appareil. Quand un chariot est utilisé, faites attention en déplaçant la combinaison d'appareil/chariot pour éviter de se déséquilibrer.
13. Arrachez la fiche du dispositif durant éclair et orage ou quand pas utilisé pour longues périodes de temps.
14. Référez au personnel qualifié de service pour toutes réparations. La réparation est donnée quand le système a été endommagé à n'importe façon, par exemple un fil ou une fiche endommagé(e) de la source d'alimentation. Avoir été exposé à pluie ou humidité, n'opère pas normalement, ou avoir été tombé.
15. L'appareil ne doit pas être exposé aux écoulements ou aux éclaboussures et aucun objet ne contenant de liquide, tel qu'un vase, ne doit être placé sur l'objet.
16. Branchez l'appareil à une source appropriée et faire que la prise à débrancher soit facilement accessible.
17. La prise du secteur ne doit pas être obstruée ou doit être facilement accessible pendant son utilisation. Pour être complètement déconnecté de l'alimentation d'entrée, la prise doit être débranchée du secteur.
18. **AVERTISSEMENT:** Pour éviter le risque d'incendie ou de chocs électriques, ne pas exposer cet appareil à la pluie ou à l'humidité.
19. Un appareil avec la borne de terre de protection doit être connecté au secteur avec la connexion de terre de protection.
20. Assurez-vous que l'appareil est hors tension avant de connecter les hauts parleurs. Vérifiez que la sortie des enceintes soit protégées contre un contact physique. Respecter les polarités des terminaux ainsi que le câblage des enceintes pendant le fonctionnement afin d'assurer une utilisation sécurisée.





AMPAV30

The Australian Monitor AMPAV30 is an active three-way stereo speaker system consisting of one powered and one passive speaker. The speakers are compact, architecturally pleasing and come supplied with adjustable mounting brackets.

Features include an on-board 15 W stereo amplifier, Treble, Bass and Volume controls as well as unbalanced stereo RCA and 3.5 mm TRS jack line inputs.

The AMPAV30 features a 5.25" bass driver, 0.5" dynamic mid-range tweeter and a 1" piezo high frequency tweeter delivering a solid 2 x 15 watts RMS of clear, intelligible power.

The Australian Monitor AMPAV series powered speakers deliver a new standard of high quality sound reinforcement for a variety of audio visual applications. Compact and well designed, they are easy to operate and are set to become the standard in many AV installations. The speakers are available in white (AMPAV30W) and black (AMPAV30B).

INTRODUCTION	3
AMPAV30 FRONT PANEL – ACTIVE & PASSIVE	4
AMPAV30 REAR PANEL – ACTIVE & PASSIVE	5
MOUNTING	6
SPECIFICATIONS	7

Revision 1.1 February 2016

WARNING!

TO PREVENT FIRE OR SHOCK HAZARD, DO NOT USE THE PLUG WITH AN EXTENSION CORD, RECEPTACLE OR OTHER OUTLET UNLESS THE BLADES CAN BE FULLY INSERTED TO PREVENT BLADE EXPOSURE.

TO REDUCE THE RISK OF FIRE OR ELECTRIC SHOCK, DO NOT EXPOSE THIS APPLIANCE TO RAIN OR MOISTURE.

TO PREVENT ELECTRICAL SHOCK, MATCH WIDE BLADE PLUG TO WIDE SLOT & FULLY INSERT.

CAUTION

THESE SERVICING INSTRUCTIONS ARE FOR USE BY QUALIFIED SERVICE PERSONNEL ONLY. TO REDUCE THE RISK OF ELECTRIC SHOCK DO NOT PERFORM ANY SERVICING OTHER THAN THAT CONTAINED IN THE OPERATING INSTRUCTIONS UNLESS YOU ARE QUALIFIED TO DO SO.



The lightning flash with arrowhead symbol, within an equilateral triangle, is intended to alert the user to the presence of uninsulated "dangerous voltage" within the product's enclosure that may be of sufficient magnitude to constitute a risk of electric shock to persons.



WARNING:
TO REDUCE THE RISK OF ELECTRIC SHOCK, DO NOT REMOVE COVER (OR BACK). NO USER SERVICEABLE PARTS INSIDE. REFER SERVICING TO QUALIFIED SERVICE PERSONNEL.



The exclamation point within an equilateral triangle is intended to alert the user to the presence of important operating and maintenance (servicing) instructions in the literature accompanying the appliance.



For European Union countries: This symbol on the product or its packaging indicates that this product must not be disposed of with other waste. Instead, it is your responsibility to dispose of your waste equipment by handing it over to a designated collection point for the recycling of waste electrical and electronic equipment. Please contact your local authority for further details of your nearest designated collection point.

Rating plate and caution marking are marked on the back enclosure of the apparatus



AMPAV30 FRONT PANEL – ACTIVE AND PASSIVE

GRILL REMOVED

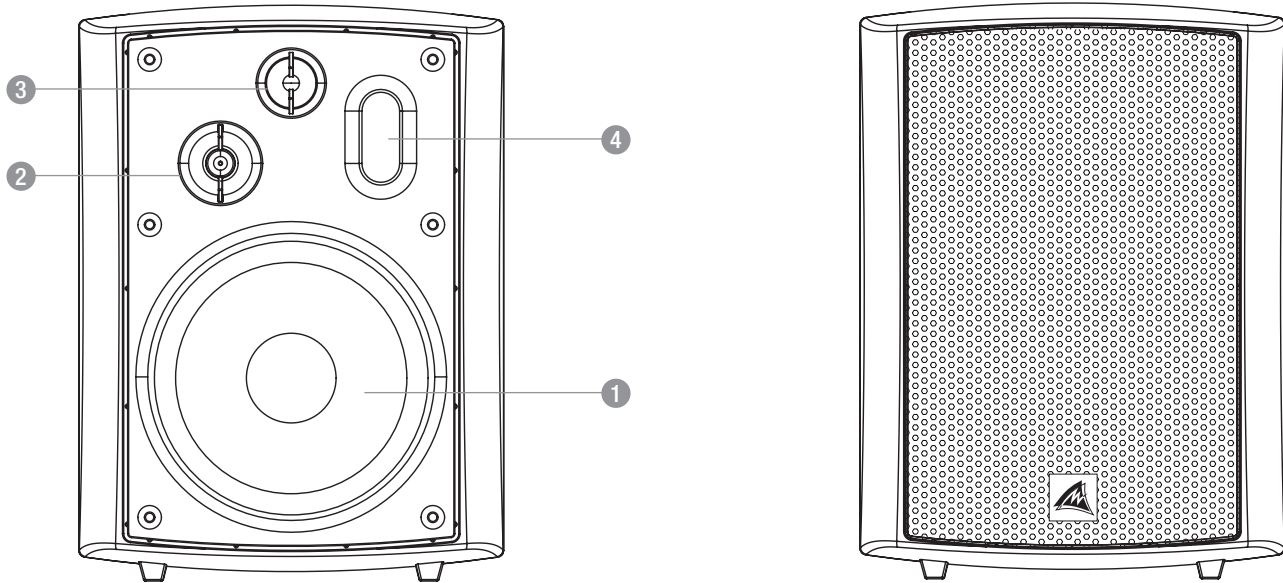

- 1 5.25" Bass Driver
- 2 0.5" Dynamic Tweeter
- 3 1.0" Piezo Tweeter
- 4 Bass Port



ACTIVE

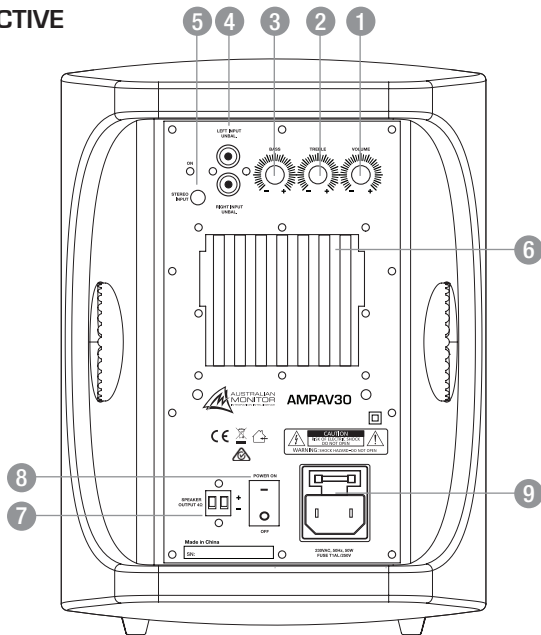

PASSIVE

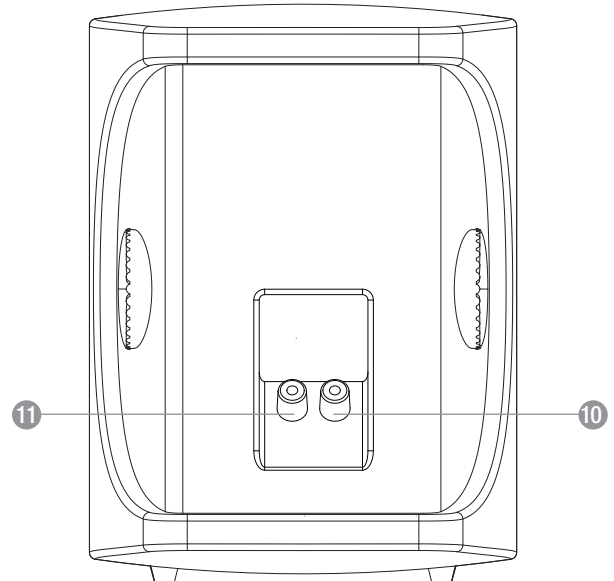

1 Volume

This control provides adjustment of the volume level of both the active and passive speakers.

2 Treble

The Treble control allows you to adjust the high frequency response of the speakers. Increasing the treble improves the intelligibility of the speech whilst decreasing the treble removes any unwanted high frequency sibilance.

3 Bass

The Bass control allows you to adjust the lower frequency response of the speakers. By adding more bass you can add depth to your sound source whilst decreasing bass can improve the intelligibility of speech.

4 L / R Inputs

Unbalanced stereo RCA inputs (Left and Right) are provided for connection of devices such as CD and DVD players, computers, data projector audio etc.

5 Stereo Input

A standard, line level 3.5 mm stereo socket is provided for easy connection of computers, MP3 players, data projector audio and other portable audio devices.

NOTE: Only one AMPAV30 input should be used at any time to avoid compromising the performance of the speaker.

Because both the RCA and 3.5 mm unbalanced inputs are set at "line level" to suit most external audio sources, the inputs are not suitable for connecting a microphone directly. This requires a suitable microphone mixer as the output level of a microphone is considerably lower than line level sources.

6 Heat Sink

⚠ When using your speakers at full power and over a long period, the heat sink may become hot, this is normal, do not touch it! Take care not to place speaker too close to other items that may be heat sensitive.

Be careful during installation not to route any cabling through the heat sink area as damage may occur.

7 Speaker Output 4 Ohm

Connection to the passive 4 Ohm external speaker is provided through a two pin terminal socket which comes fitted with a removable screw terminal plug. The passive speaker becomes the right hand channel whilst the left channel is the active speaker. Connect the supplied figure 8 or a similar speaker cable between the active and passive speaker. Be sure that the "+" of the main unit socket is connected to the "+" (red terminal post) of the passive loudspeaker and the "-" of the main unit is connected to the "-" (black terminal post) of the passive speaker.

Never connect the active Speaker Output terminal to an external speaker that is not the correct 4 Ohm impedance.

8 Power On/Off

⚡ The Power switch turns the speaker system on and off. When the unit is switched on, a green ON LED will illuminate to indicate that the system is operational. Always ensure that the power is turned off when connecting or disconnecting the speaker cabling to the speaker.

9 Power supply socket

⚡ The integrated IEC and fuse holder socket is fitted with a 1 Amp slow blow fuse. Should the fuse require replacement, use a screw driver to open the fuse compartment. A spare fuse is contained in the tray under the IEC socket. Always ensure that a 1 A slow blow fuse is used. Always ensure that the power is turned off and the mains lead is removed from the wall socket before changing a fuse.

10 Positive Terminal

11 Negative Terminal



MOUNTING

MOUNTING

! When mounting AMPAV speakers the following safety issues must be considered.

The mounting of a permanently installed speaker may be dangerous unless undertaken by a qualified professional with relevant experience.

Walls and mounting surfaces must be capable of supporting the speaker and bracket in a safe and secure manner.

All fixings must be safely attached to the speaker cabinet and the mounting surface.

All fixings must be installed in accordance with the manufacturer's instructions and specifications.

MOUNTING BRACKETS

The AMPAV speakers are supplied with horizontal wall mount U brackets allowing adjustment in the vertical plane.

Slots for mounting the brackets are 5 mm wide and spaced 80 mm apart. The design of the slots allows for the bracket to be easily mounted and removed. Simply secure the bracket to the wall using suitable fittings but always ensure that they are fit for purpose. Once the bracket is secure, mount the speaker to the bracket and connect wiring.

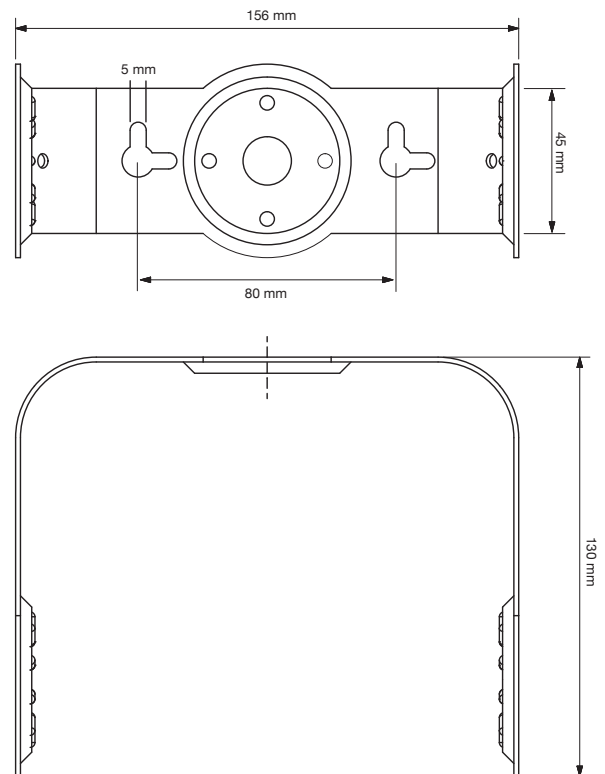
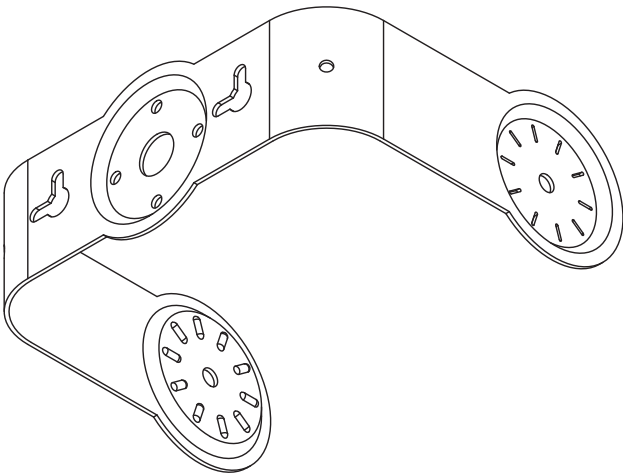



SPECIFICATIONS

AMPAV30

Speaker system	3-Way Active Speaker 3-Way Passive Speaker
Power (Continuous)	2 x 15 Watts
Impedance	4 Ohms
Sensitivity (1 W / 1 M)	88 dB
Calculated max SPL (per speaker)	100 dB
Frequency Response (-3 dB)	45 Hz – 20 kHz
Frequency Response (-10 dB)	40 Hz – 22 kHz
Speaker Components Woofer	134 mm (5.25") Polypropylene 25 mm (1") Piezo Tweeter 12.5 mm (0.5") Dynamic Tweeter
Mains Power Requirement	230 VAC, 50 Hz, 50 W
Dimensions (W x H x D) (each speaker)	178 x 240 x 193 mm (7" x 9.4" x 7.5")
Dimensions (W x H x D) (boxed pair)	465 x 270 x 205 mm (18.3" x 10.6" x 8.1")
Weight (active speaker)	2.8 kg (6.2 lbs)
Weight (passive speaker)	1.9 kg (4.2 lbs)
Gross Weight per pair (box)	5.8 kg (12.7 lbs)
Accessories (supplied)	Passive Speaker Wall brackets (pair) Bracket fixing "dials" (pair) 1.65 M IEC mains cord 2.6 M Figure-8 speaker wire Installation & Operation Manual



ENGINEERED BY AUSTRALIAN MONITOR

Address: 1 Clyde Street, Silverwater NSW 2128 Australia.

Website: www.australianmonitor.com.au International enquiries email: international@australianmonitor.com.au